

# Transient Voltage Suppression Diodes: TPSMBJ Series

## SMD Type 600 W



### ■ Features

1. For surface mounted applications
2. RoHS compliant and halogen-free
3. Reliable low cost construction utilizing molded plastic technique
4. Glass passivated chip junction
5. Both bi-directional and uni-directional devices are available
6. Fast response time
7. Low leakage
8. Excellent clamping capability
9. 600W peak pulse power capability with a 10/1000 $\mu$ s waveform, repetitive rate (duty cycle): 0.01%
10. High reliability application and automotive grade AEC Q101 qualified



### ■ Recommended Applications

1. Telecommunication
2. Computer
3. Industrial device
4. Consumer electronic device
5. Automotive

### ■ Mechanical Data

1. Case: DO-214AA (SMB), molded plastic meets UL flammability rating 94V-0
2. Terminal: Matte Tin-plated leads, solderable per MIL-STD-750, Method 2026.
3. Polarity: The band denotes cathode (Note: no polarity indicator for bi-directional devices)

### ■ Part Number Code

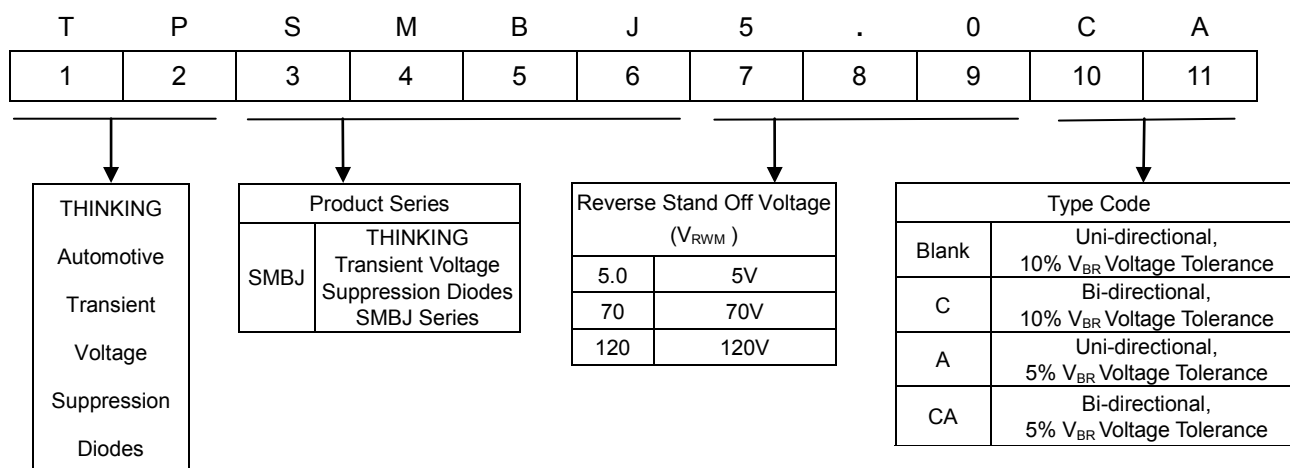

### ■ Structures and Dimensions

#### SMB-DO214AA

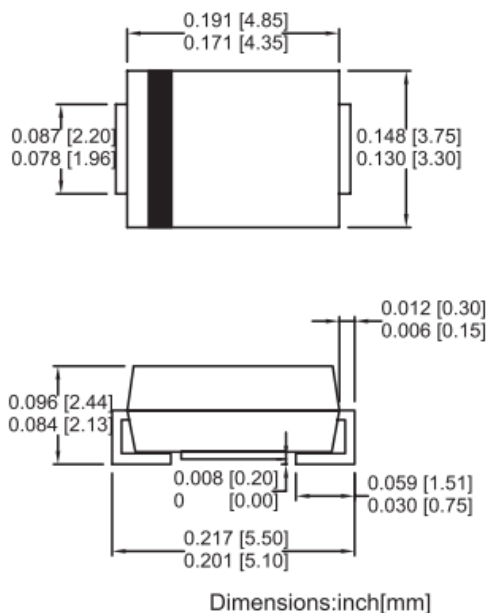

### ■ Maximum Rating (TA=25°C unless otherwise noted)

Parameter	Symbol	Value	Unit
Peak pulse power dissipation at TA=25°C by 10/1000µs waveform (Note1)	P <sub>PPM</sub>	600	W
Peak pulse current of on 10/1000us waveform (Note1)	I <sub>PPM</sub>	See Table	A
Peak forward surge current, 8.3ms single half sine wave on rated load (Note 2)	I <sub>FSM</sub>	100	A
Power dissipation on infinite heatsink at TL=75°C	P <sub>D</sub>	5.0	W
Operating junction and storage temperature range	T <sub>J</sub> , T <sub>STG</sub>	-55~+150	°C

Note: 1. Please refer to Fig. 5 for non-repetitive current pulse, and Fig. 1 for derated above TA = 25°C.

2. 8.3ms single half sine-wave, or square wave that has a maximum of 4 pulses per minute.

# Transient Voltage Suppression Diodes: TPSMBJ Series

## SMD Type 600 W



### ■ Electrical Characteristics (T<sub>A</sub>=25°C unless otherwise noted)

Part No. (Uni)	Part No. (Bi)	Reverse Stand off Voltage	Breakage Voltage VBR @ IT		Test Current IT( mA )	Maximum Clamping Voltage VC @ Ipp	Maximum Peak Pulse Current Ipp(A)	Maximum Reverse Leakage IR @VRWM	Marking Code	
			VRWM ( V )	Min( V )					Max( V )	UNI
TPSMBJ11A	TPSMBJ11CA	11	12.2	13.5	1	18.2	32.97	1	KZA	AZA
TPSMBJ12A	TPSMBJ12CA	12	13.3	14.7	1	19.9	30.15	1	LEA	BEA
TPSMBJ13A	TPSMBJ13CA	13	14.4	15.9	1	21.5	27.91	1	LGA	BGA
TPSMBJ14A	TPSMBJ14CA	14	15.6	17.2	1	23.2	25.86	1	LKA	BKA
TPSMBJ15A	TPSMBJ15CA	15	16.7	18.5	1	24.4	24.59	1	LMA	BMA
TPSMBJ16A	TPSMBJ16CA	16	17.8	19.7	1	26	23.08	1	LPA	BPA
TPSMBJ17A	TPSMBJ17CA	17	18.9	20.9	1	27.6	21.74	1	LRA	BRA
TPSMBJ18A	TPSMBJ18CA	18	20	22.1	1	29.2	20.55	1	LTA	BT A
TPSMBJ19A	TPSMBJ19CA	19	21.1	23.3	1	30.8	19.49	1	LBA	BBA
TPSMBJ20A	TPSMBJ20CA	20	22.2	24.5	1	32.4	18.52	1	LVA	BVA
TPSMBJ22A	TPSMBJ22CA	22	24.4	26.9	1	35.5	16.90	1	LXA	BXA
TPSMBJ24A	TPSMBJ24CA	24	26.7	29.5	1	38.9	15.42	1	LZA	BZA
TPSMBJ26A	TPSMBJ26CA	26	28.9	31.9	1	42.1	14.25	1	MEA	CEA
TPSMBJ28A	TPSMBJ28CA	28	31.1	34.4	1	45.4	13.22	1	MGA	CGA
TPSMBJ30A	TPSMBJ30CA	30	33.3	36.8	1	48.4	12.40	1	MKA	CKA
TPSMBJ33A	TPSMBJ33CA	33	36.7	40.6	1	53.3	11.26	1	MMA	CMA
TPSMBJ36A	TPSMBJ36CA	36	40	44.2	1	58.1	10.33	1	MPA	CPA
TPSMBJ40A	TPSMBJ40CA	40	44.4	49.1	1	64.5	9.30	1	MRA	CRA
TPSMBJ43A	TPSMBJ43CA	43	47.8	52.8	1	69.4	8.65	1	MTA	CTA
TPSMBJ45A	TPSMBJ45CA	45	50	55.3	1	72.7	8.25	1	MVA	CVA
TPSMBJ48A	TPSMBJ48CA	48	53.3	58.9	1	77.4	7.75	1	MXA	CXA
TPSMBJ51A	TPSMBJ51CA	51	56.7	62.7	1	82.4	7.28	1	MZA	CZA
TPSMBJ54A	TPSMBJ54CA	54	60	66.3	1	87.1	6.89	1	NEA	DEA
TPSMBJ58A	TPSMBJ58CA	58	64.4	71.2	1	93.6	6.41	1	NGA	DGA
TPSMBJ60A	TPSMBJ60CA	60	66.7	73.7	1	96.8	6.20	1	NKA	DKA
TPSMBJ64A	TPSMBJ64CA	64	71.1	78.6	1	103	5.83	1	NMA	DMA
TPSMBJ70A	TPSMBJ70CA	70	77.8	86	1	113	5.31	1	NPA	DPA
TPSMBJ75A	TPSMBJ75CA	75	83.3	92.1	1	121	4.96	1	NRA	DRA
TPSMBJ78A	TPSMBJ78CA	78	86.7	95.8	1	126	4.76	1	NTA	DTA
TPSMBJ85A	TPSMBJ85CA	85	94.4	104	1	137	4.38	1	NVA	DVA
TPSMBJ90A	TPSMBJ90CA	90	100	111	1	146	4.11	1	NXA	DXA

# Transient Voltage Suppression Diodes: TPSMBJ Series

## SMD Type 600 W



### ■ Electrical Characteristics ( $T_A=25^\circ\text{C}$ unless otherwise noted)

Part No. (Uni)	Part No. (Bi)	Reverse Stand off Voltage	Breakage Voltage VBR @ IT		Test Current IT ( mA )	Maximum Clamping Voltage VC @ Ipp	Maximum Peak Pulse Current Ipp(A)	Maximum Reverse Leakage IR @VRWM	Marking Code	
			VRWM ( V )	Min( V )					Max( V )	UNI
TPSMBJ100A	TPSMBJ100CA	100	111	123	1	162	3.70	1	NZA	DZA
TPSMBJ110A	TPSMBJ110CA	110	122	135	1	177	3.39	1	PEA	EEA
TPSMBJ120A	TPSMBJ120CA	120	133	147	1	193	3.11	1	PGA	EGA
TPSMBJ130A	TPSMBJ130CA	130	144	159	1	209	2.87	1	PKA	EKA
TPSMBJ140A	TPSMBJ140CA	140	155	171	1	226.8	2.65	1	PBA	EBA
TPSMBJ150A	TPSMBJ150CA	150	167	185	1	243	2.47	1	PMA	EMA
TPSMBJ160A	TPSMBJ160CA	160	178	197	1	259	2.32	1	PPA	EPA
TPSMBJ170A	TPSMBJ170CA	170	189	209	1	275	2.18	1	PRA	ERA

Note:

1. Add suffix "C" or "CA" after part number to specify Bi-directional devices.
2. For bidirectional type having  $V_{RWM}$  of 10 volts and under, the  $I_R$  limit is doubled.

# Transient Voltage Suppression Diodes: TPSMBJ Series

## SMD Type 600 W



### ■ Rate and Characteristic Curve ( $T_A=25^\circ\text{C}$ unless otherwise noted)

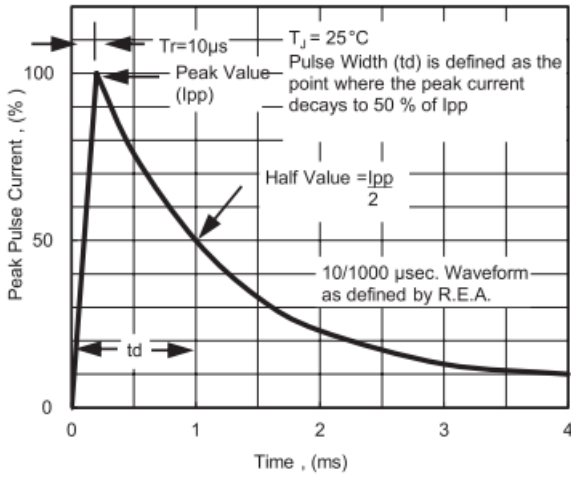

Fig. 5 - Pulse Waveform

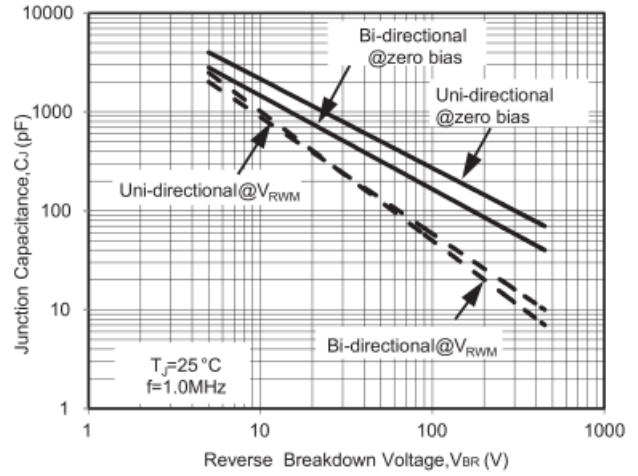

Fig. 6 - Typical Junction Capacitance

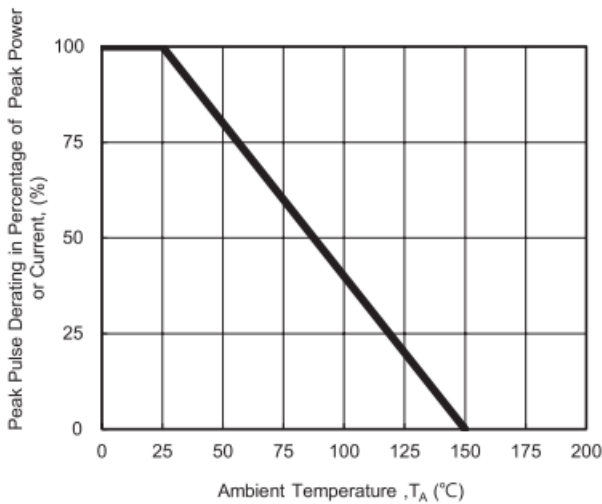

Fig. 1 - Pulse Derating Curve

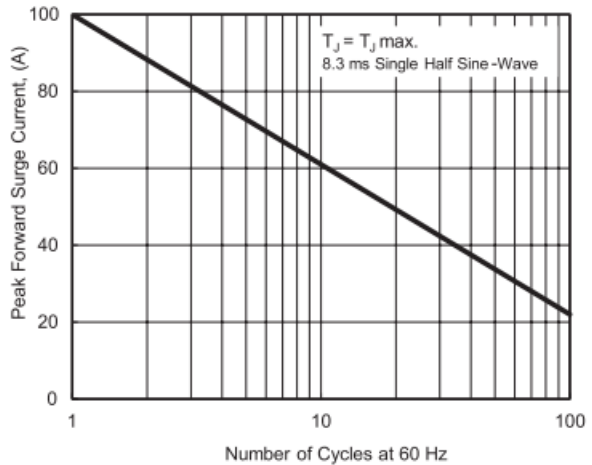

Fig. 2 - Maximum Non-Repetitive Surge Current

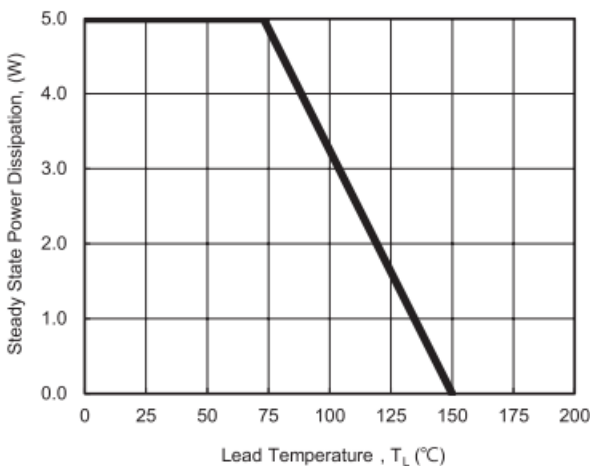

Fig. 3 - Steady State Power Derating Curve

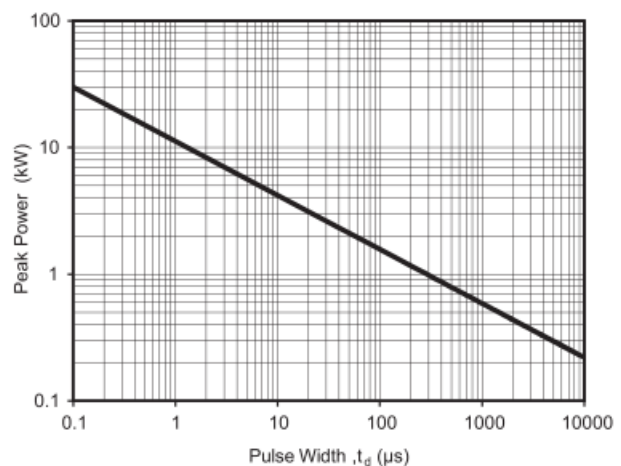

Fig. 4 - Peak Pulse Power Rating Curve

# Transient Voltage Suppression Diodes: TPSMBJ Series

## SMD Type 600 W



### IR-reflow soldering profile

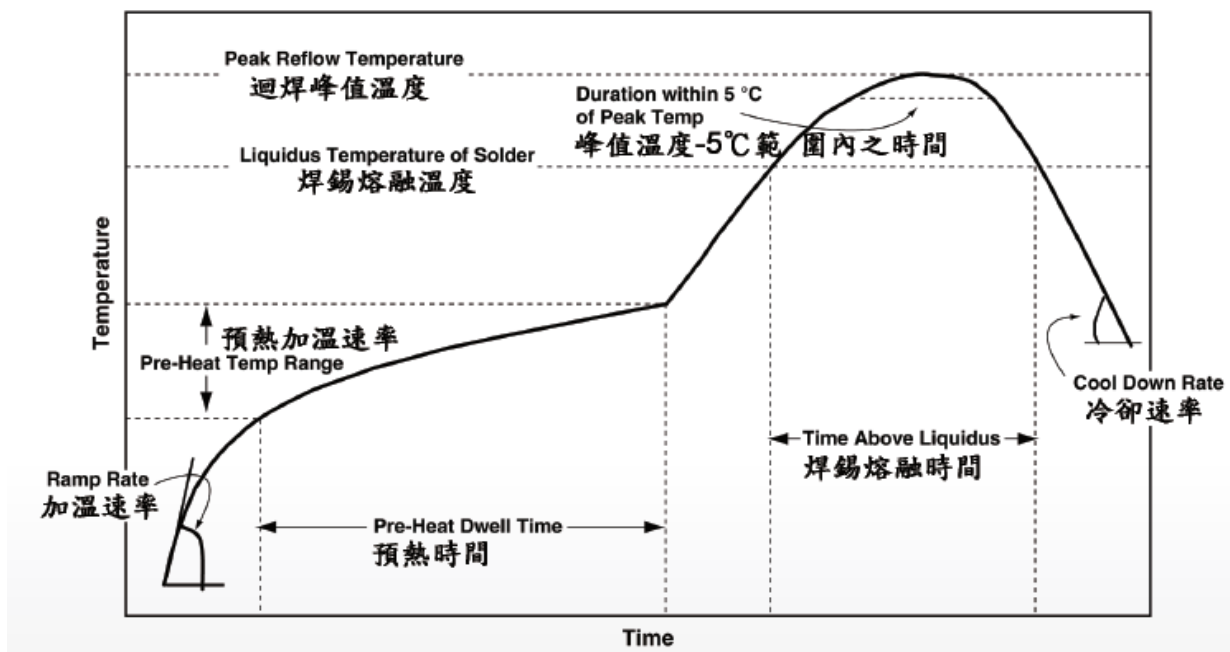

LEAD(Pb)-FREE SOLDER(SnAgCu) REFLOW PROFILE ATTRIBUTES	
PROFILE ATTRIBUTE	PROFILE ATTRIBUTE
Peak Reflow Temperature	250(+10/-5)°C
Time within 5°C of Peak Temperature	30s max
Liquidus Temperature of Solder	217°C
Cool Down Rate	6 °C/s max
Time above Liquidus	60s to 150s
Pre-heat Temperature Range	150°C to 200°C
Pre-heat Dwell Time	60s to 120s
Maximum Ramp Rate	3 °C/s max

# Transient Voltage Suppression Diodes: TPSMBJ Series

## SMD Type 600 W



### ■ Packaging

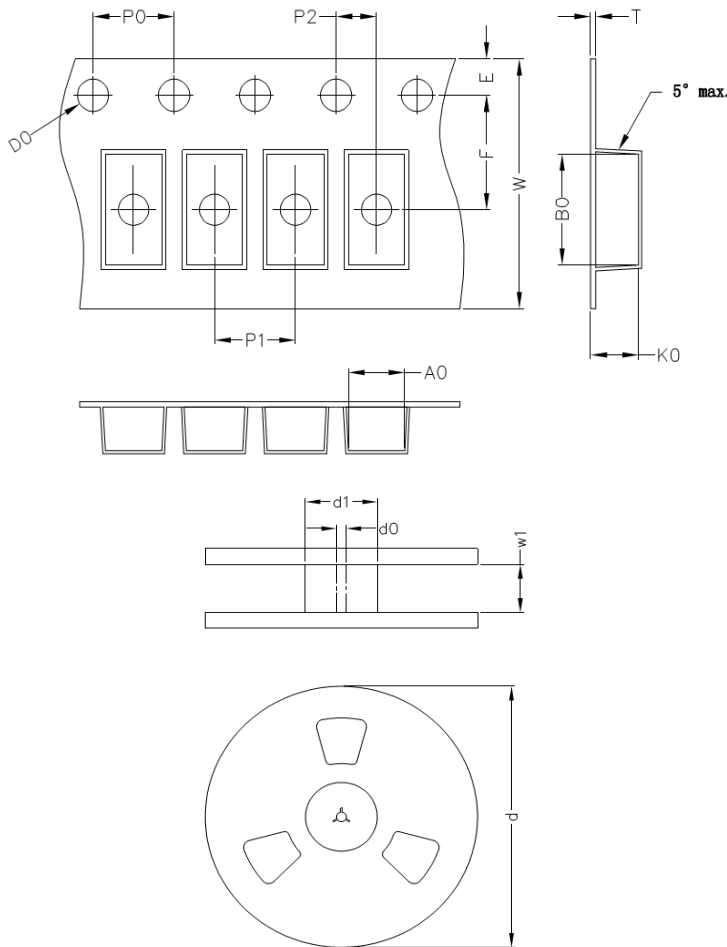

Item	Symbol	DO-214AA (SMB) Unit: mm
Carrier width	A0	3.8
Carrier length	B0	5.4
Carrier depth	K0	2.45
Sprocket hole	D0	1.55
Sprocket hole position	E	1.75
Punch hole position	F	5.5
Sprocket hole pitch	P0	4
Carrier pitch	P1	8
Embossment center	P2	2
Tape thickness	T	0.4
Tape width	W	12
Reel outside diameter	d (13")	330
Reel inner diameter	d1	50
Feed hole diameter	d0	13.5
Reel inner width	w1	14.5

Note: The tolerance of carrier tape and top cover is  $\pm 0.1\text{mm}$ , and the tolerance of reel is  $\pm 2\text{mm}$

### ■ Quantity

**MPQ: 3,000pcs**

Package Type	Reel Size	Reel	Inner Box
	inch	Kpcs	Kpcs
DO-214AA	13	3	6

### ■ Warehouse Storage Conditions of product

- Storage Condition:
  - Storage Temperature: 15~30°C
  - Relative Humidity:  $\leq 75\%RH$
  - Keep away from corrosive atmosphere and sunlight.
- Period of Storage: 1 year.